

WINGNUTS AND T HANDLES



BOTECO[®]

ALL PURPOSE HANDGRIPS

ART. L270

T HANDLE WITH THREADED INSERT

MATERIAL:

Reinforced polyamide.
Oils and greases resistant.

SURFACE:

Satin.

COLOUR:

Black (RAL 9011).

MAIN INSERT:

Brass blind threaded bush.

SPECIAL REQUESTS:

- It is possible to supply the inserts in different materials, on request and for quantities.
- It is possible to supply colours as shown in the table at page 19, on request and for quantities.

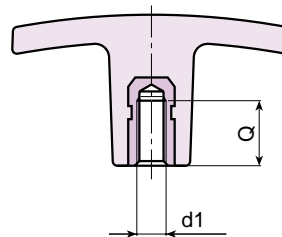
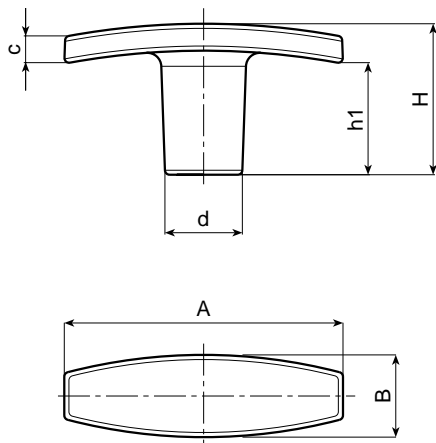

Art.	A	B	H	h1	c	d	d1	Q	Weight (gr)	F1 (N)
L270-50 M5	50	15	24	17	5	14	M5	12	13	4100
L270-50 M6	50	15	24	17	5	14	M6	10	11	4100
L270-50 M8	50	15	24	17	5	14	M8	14	12	4100
L270-60 M5	60	18	33	24	6	16,5	M5	12	19	5800
L270-60 M6	60	18	33	24	6	16,5	M6	10	16,5	5800
L270-60 M8	60	18	33	24	6	16,5	M8	14	17,5	5800
L270-60 M10	60	18	33	24	6	16,5	M10	21	21	5800
L270-72 M6	72	19	34	20	10	18	M6	15	25	6500
L270-72 M8	72	19	34	20	10	18	M8	20	28	6500
L270-72 M10	72	19	34	20	10	18	M10	21	30	6500
L270-72 M12	72	19	34	20	10	18	M12	17	30	6500



BOTECA

ART. L271

T HANDLE WITH THREADED STUD

MATERIAL:

Reinforced polyamide.
Oils and greases resistant.

SURFACE:

Satin.

COLOUR:

Black (RAL 9011).

MAIN INSERT:

Zinc plated steel threaded stud.

SPECIAL REQUESTS:

- It is possible to supply the inserts with different lengths, on request and for quantities.
- It is possible to supply the inserts in different materials, on request and for quantities.
- It is possible to supply colours as shown in the table at page 19, on request and for quantities.

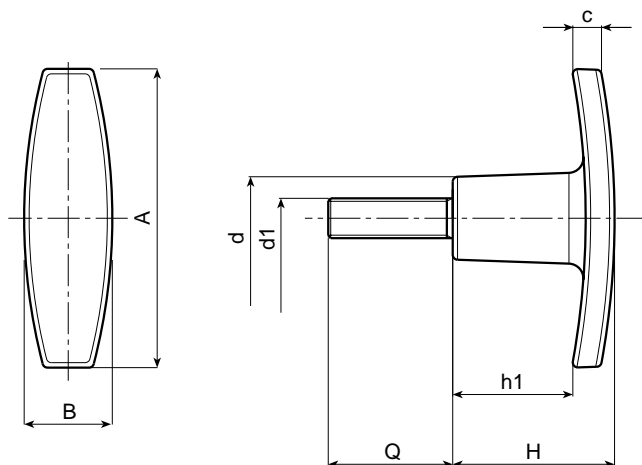

Art.	A	B	H	h1	c	d	d1	Q	Weight (gr)	F1 (N)
L271-50 M5	50	15	24	17	5	14	M5	20-30-40	13-14-15	4100
L271-50 M6	50	15	24	17	5	14	M6	20-30-40	15-16,5-18	4100
L271-60 M5	60	18	33	24	6	16,5	M5	20-30-40	20-21-22,5	4100
L271-60 M6	60	18	33	24	6	16,5	M6	20-30-40	23-25-27	5800
L271-60 M8	60	18	33	24	6	16,5	M8	20-30-40	27,5-31-34	5800
L271-60 M10	60	18	33	24	6	16,5	M10	20-30-40	30-35-38	5800
L271-72 M6	72	19	34	20	10	18	M6	20-30-40	30-32-34	6500
L271-72 M8	72	19	34	20	10	18	M8	20-30-40-50	36-42-45-48	6500
L271-72 M10	72	19	34	20	10	18	M10	30-40-50	56-61-66	6500
L271-72 M12	72	19	34	20	10	18	M12	30-40-50	58-64-71	6500



BOTECA

ART. L272

T HANDLE WITH HOLE THREADED INTO THE PLASTIC

MATERIAL:

Reinforced polyamide.
Oils and greases resistant.

SURFACE:

Satin.

COLOUR:

Black (RAL 9011).

HOLE :

Female threaded blind hole obtained by moulding the plastic.

SPECIAL REQUESTS:

- It is possible to supply colours as shown in the table at page 19, on request and for quantities.

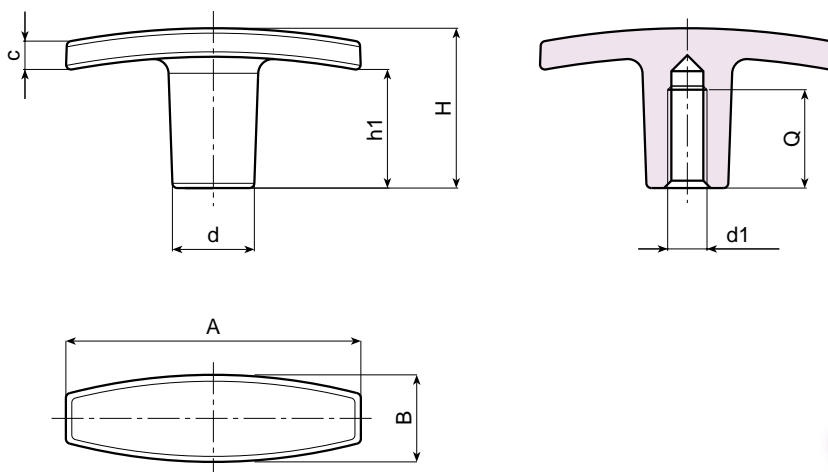

Art.	A	B	H	h1	c	d	d1	Q	Weight (gr)	F1 (N)
L272-50 M5	50	15	24	17	5	14	M5	20	8	2800
L272-50 M6	50	15	24	17	5	14	M6	20	8	2800
L272-50 M8	50	15	24	17	5	14	M8	20	7	2800
L272-60 M5	60	18	33	24	6	16,5	M5	19	14	3000
L272-60 M6	60	18	33	24	6	16,5	M6	19	14	3000
L272-60 M8	60	18	33	24	6	17	M8	19	14	3000
L272-60 M10	60	18	33	24	6	18	M10	19	13	3000
L272-72 M8	72	19	34	20	10	18	M8	21	20	4600
L272-72 M10	72	19	34	20	10	18	M10	21	20	4600
L272-72 M12	72	19	34	20	10	18	M12	20	19	4600



BOTECA

ART. L273

T HANDLE WITH SMOOTH HOLE INSERT

MATERIAL:

Reinforced polyamide.
Oils and greases resistant.

SURFACE:

Satin.

COLOUR:

Black (RAL 9011).

MAIN INSERT:

Brass blind bored bush with H7 tolerance.
(*) Zinc plated steel blind bored bush with H7 tolerance.



SPECIAL REQUESTS:

- It is possible to supply the inserts with d1 diameter by customer design, on request and for quantities.
- It is possible to supply the inserts in different materials, on request and for quantities.
- It is possible to supply colours as shown in the table at page 19, on request and for quantities.

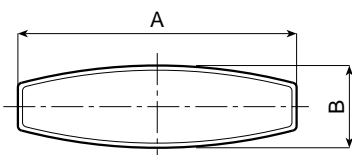
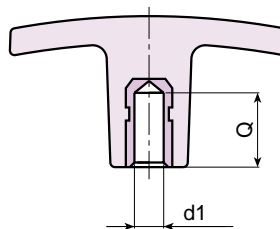
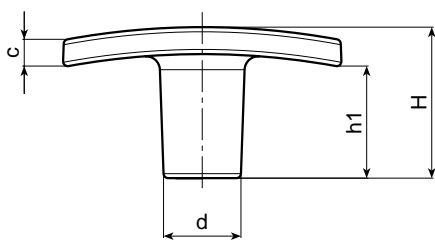

Art.	A	B	H	h1	c	d	d1 (H7)	Q	Weight (gr)	F1 (N)
L273-50 6	50	15	24	17	5	14	6	16	12	4100
L273-60 6	60	18	33	24	6	16,5	6	16	19	5800
L273-60 8	60	18	33	24	6	16,5	8	15	21	5800
L273-72 8	72	19	34	20	10	18	8	15	28	6500
L273-72 10	72	19	34	20	10	18	(*) 10	17	30	6500



BOTECA

ART. L270 CIN

T HANDLE WITH THREADED STAINLESS STEEL INSERT

INOX

MATERIAL:

Reinforced polyamide.
Oils and greases resistant.

SURFACE:

Satin.

COLOUR:

Black (RAL 9011).

MAIN INSERT:

Stainless steel threaded blind bush (AISI 303).

SPECIAL REQUESTS:

- It is possible to supply colours as shown in the table at page 19, on request and for quantities.

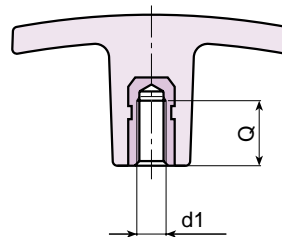
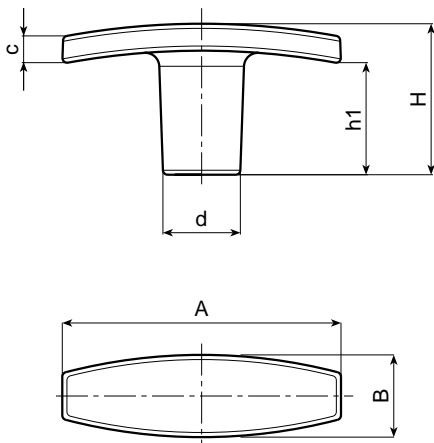

Art.	A	B	H	h1	c	d	d1	Q	Weight (gr)	F1 (N)
L270-50 M5 CIN	50	15	24	17	5	14	M05	9	14	4100
L270-50 M6 CIN	50	15	24	17	5	14	M06	9	14	4100
L270-50 M8 CIN	50	15	24	17	5	14	M08	12	16	4100
L270-60 M6 CIN	60	18	33	24	6	16,5	M06	9	20	5800
L270-60 M8 CIN	60	18	33	24	6	16,5	M08	12	21	5800
L270-60 M10 CIN	60	18	33	24	6	16,5	M10	18	24	5800
L270-72 M8 CIN	72	19	34	20	10	18	M08	19	32	6500
L270-72 M10 CIN	72	19	34	20	10	18	M10	18	33	6500
L270-72 M12 CIN	72	19	34	20	10	18	M12	15	34	6500



BOTECA

ART. L271 CIN

T HANDLE WITH THREADED STAINLESS STEEL STUD

INOX

MATERIAL:

Reinforced polyamide.
Oils and greases resistant.

SURFACE:

Satin.

COLOUR:

Black (RAL 9011).

MAIN INSERT:

Stainless steel threaded stud (AISI 303).

SPECIAL REQUESTS:

- It is possible to supply the inserts with different lengths, on request and for quantities.
- It is possible to supply colours as shown in the table at page 19, on request and for quantities.

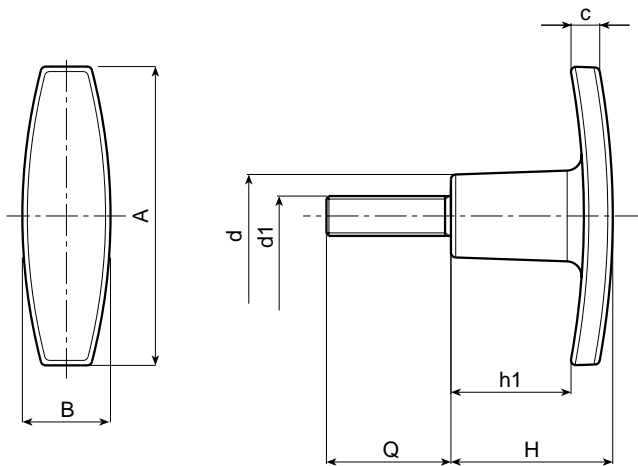

Art.	A	B	H	h1	c	d	d1	Q	Weight (gr)	F1 (N)
L271-50 M5 CIN	50	15	24	17	5	14	M5	30	15	4100
L271-50 M6 CIN	50	15	24	17	5	14	M6	30	17	4100
L271-60 M6 CIN	60	18	33	24	6	16,5	M6	40	25	5800
L271-60 M8 CIN	60	18	33	24	6	16,5	M8	40	31	5800
L271-72 M8 CIN	72	19	34	20	10	18	M8	40	43	6500
L271-72 M10 CIN	72	19	34	20	10	18	M10	40	57	6500
L271-72 M12 CIN	72	19	34	20	10	18	M12	40	65	6500



BOTECA

ART. L750

WINGNUT WITH THREADED INSERT

MATERIAL:

Reinforced polyamide.
Oils and greases resistant.

SURFACE:

Satin.

COLOUR:

Black (RAL 9011).
Orange (RAL 2004).

MAIN INSERT:

Brass blind threaded bush.



SPECIAL REQUESTS:

- It is possible to supply the inserts in different materials, on request and for quantities.
- It is possible to supply colours as shown in the table at page 19, on request and for quantities.

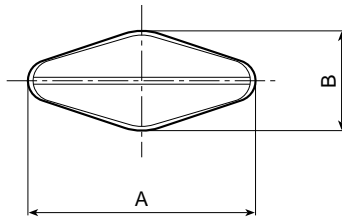
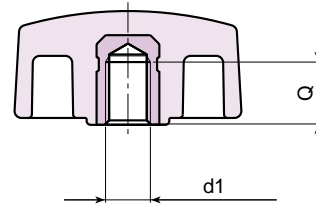
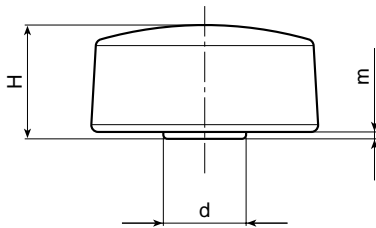

Art.	A	B	H	m	d	d1	Q	Weight (gr)
L750-32 M5	33	15	16,5	1	12	M5	7	7
L750-32 M6	33	15	16,5	1	12	M6	7	6
L750-32 M8	33	15	16,5	1	12	M8	7	6
L750-48 M6	48	15	17	1	12,5	M6	7	10
L750-48 M8	48	15	17	1	12,5	M8	7	10



ART. L751

WINGNUT WITH THREADED STUD

MATERIAL:

Reinforced polyamide.
Oils and greases resistant.

SURFACE:

Satin.

COLOUR:

Black (RAL 9011).
Orange (RAL 2004).

MAIN INSERT:

Zinc plated steel threaded stud.



SPECIAL REQUESTS:

- It is possible to supply the inserts with different lengths, on request and for quantities.
- It is possible to supply the inserts in different materials, on request and for quantities.
- It is possible to supply colours as shown in the table at page 19, on request and for quantities.

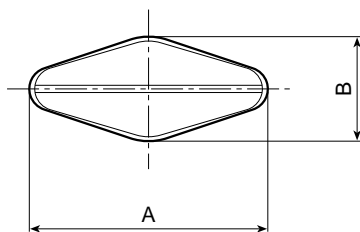
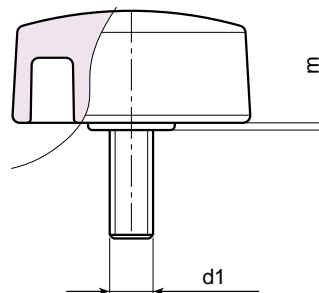
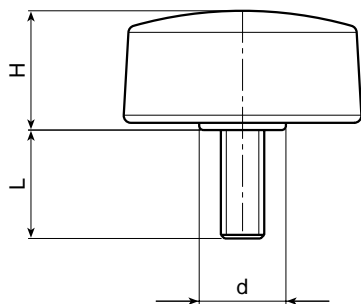

Art.	A	B	H	m	d	d1	Q	Weight (gr)
L751-32 M5	33	15	15,5	1	12	M5	10-16-20-25-30-40-50	7-8-8,5-9-11-15-18,5
L751-32 M6	33	15	15,5	1	12	M6	10-16-20-25-30-40-50	9-11-12-12-12,5-15,5-19
L751-32 M8	33	15	15,5	1	12	M8	16-20-25-30-35-40-50	14,5-16-17,5-19-20,5-22-26
L751-48 M6	48	15	17	1	12,5	M6	10-16-20-25-30-40-50	13-15-16-17-17,5-19-22
L751-48 M8	48	15	17	1	12,5	M8	16-20-25-30-35-40	18-20-21,5-23-25-27



BOTECA

ART. L750 CIN

WINGNUT WITH THREADED STAINLESS STEEL INSERT

INOX

MATERIAL:

Reinforced polyamide.
Oils and greases resistant.

SURFACE:

Satin.

COLOUR:

Black (RAL 9011).

MAIN INSERT:

Stainless steel threaded blind bush (AISI 303).

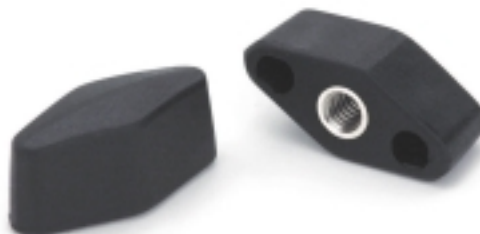

SPECIAL REQUESTS:

- It is possible to supply colours as shown in the table at page 19, on request and for quantities.

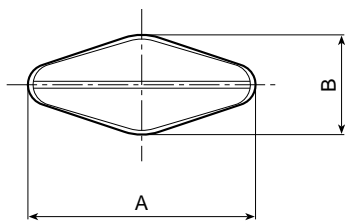
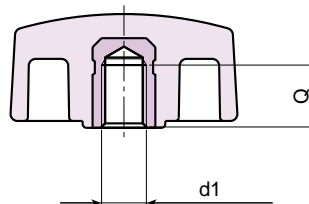
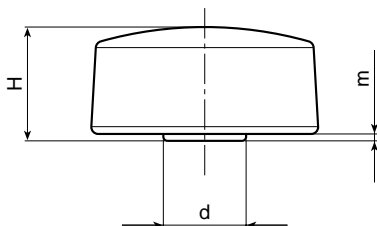

Art.	A	B	H	m	d	d1	Q	Weight (gr)
L750-32 M5 CIN	33	15	16,5	1	12	M5	7	9
L750-32 M6 CIN	33	15	16,5	1	12	M6	7	8
L750-32 M8 CIN	33	15	16,5	1	12	M8	7	8
L750-48 M8 CIN	48	15	17	1	12,5	M8	7	8

WINGNUTS AND T HANDLES



BOTECO

ART. L751 CIN

WINGNUT WITH THREADED STAINLESS STEEL STUD

INOX

MATERIAL:

Reinforced polyamide.
Oils and greases resistant.

SURFACE:

Satin.

COLOUR:

Black (RAL 9011).

MAIN INSERT:

Stainless steel threaded stud (AISI 303).



SPECIAL REQUESTS:

- It is possible to supply the inserts with different lengths, on request and for quantities.
- It is possible to supply colours as shown in the table at page 19, on request and for quantities.

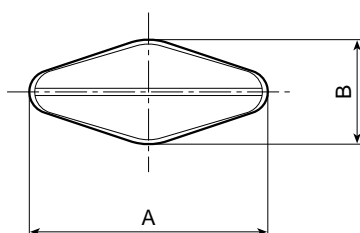
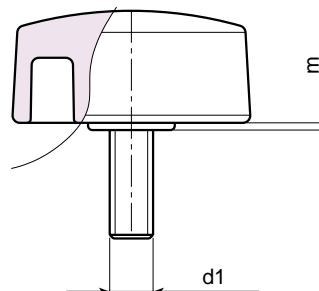
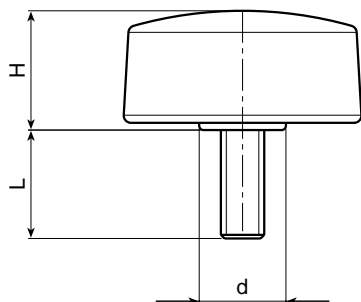

Art.	A	B	H	m	d	d1	Q	Weight (gr)
L751-32 M6 CIN	33	15	15,5	1	12	M6	16-20-25-30-40	9-9,5-10-12-16
L751-32 M8 CIN	33	15	15,5	1	12	M8	16-20-30-40	12,5-13,5-15-17
L751-48 M6 CIN	48	15	17	1	12,5	M6	20-30-40	17-18-19-22
L751-48 M8 CIN	48	15	17	1	12,5	M8	20-30-40	22-25,5-28



BOTECA

ART. L754

LARGE WINGNUT WITH THREADED INSERT

MATERIAL:

Reinforced polyamide.
Oils and greases resistant.

SURFACE:

Satin.

COLOUR:

Black (RAL 9011).

MAIN INSERT:

Brass blind threaded bush.

SPECIAL REQUESTS:

- It is possible to supply the inserts in different materials, on request and for quantities.
- It is possible to supply colours as shown in the table at page 19, on request and for quantities.

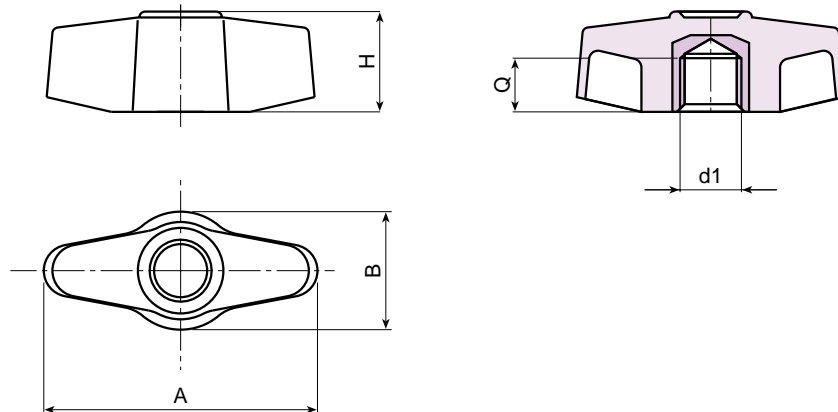

Art.	A	B	H	d1	Q	Weight (gr)
L754-48 M6	45	20	17	M6	7	11
L754-48 M8	45	20	17	M8	7	11
L754-48 M10	45	20	17	M10	6	12

W I N G N U T S A N D T H A N D L E S



BOTECO

ART. L755

LARGE WINGNUT WITH RIGHT THROUGH THREADED INSERT

MATERIAL:

Reinforced polyamide.
Oils and greases resistant.

SURFACE:

Satin.

COLOUR:

Black (RAL 9011).

MAIN INSERT:

Zinc plated steel right through threaded bush.

SPECIAL REQUESTS:

- It is possible to supply the inserts in different materials, on request and for quantities.
- It is possible to supply colours as shown in the table at page 19, on request and for quantities.

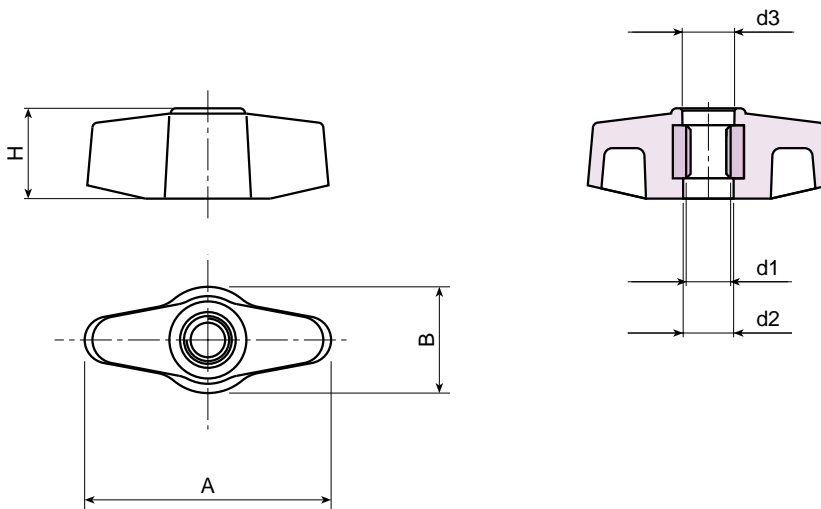

Art.	A	B	H	d1	d2	d3	Weight (gr)
L755-48 M6	45	20	17	M6	9,5	10	17
L755-48 M8	45	20	17	M8	9,5	10	16

ART. L756

LARGE WINGNUT WITH THREADED STUD

MATERIAL:

Reinforced polyamide.
Oils and greases resistant.

SURFACE:

Satin.

COLOUR:

Black (RAL 9011).

MAIN INSERT:

Zinc plated steel threaded stud.

SPECIAL REQUESTS:

- It is possible to supply the inserts with different lengths, on request and for quantities.
- It is possible to supply the inserts in different materials, on request and for quantities.
- It is possible to supply colours as shown in the table at page 19, on request and for quantities.

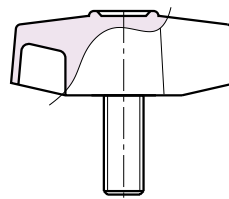
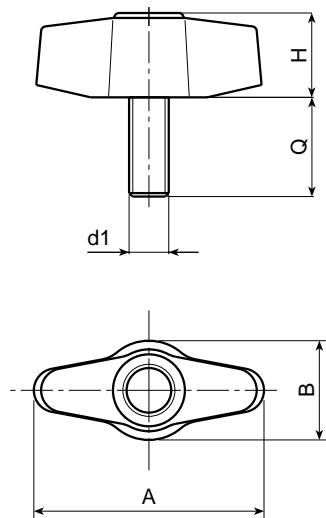

Art.	A	B	H	d1	Q	Weight (gr)
L756-48 M6	45	20	17	M6	20-25-30	15-15,5-16
L756-48 M8	45	20	17	M8	16-20-25-30-35-40-50	17-18,5-20-21,5-23-24,5-26
L756-48 M10	45	20	17	M10	20-25-30-40	26-28,5-30-35

ART. L747

28mm. WINGNUT WITH THREADED INSERT

MATERIAL:

Reinforced polyamide.
Oils and greases resistant.

SURFACE:

Satin.

COLOUR:

Black (RAL 9011).

MAIN INSERT:

Brass blind threaded bush.

SPECIAL REQUESTS:

- It is possible to supply the inserts in different materials, on request and for quantities.
- It is possible to supply colours as shown in the table at page 19, on request and for quantities.

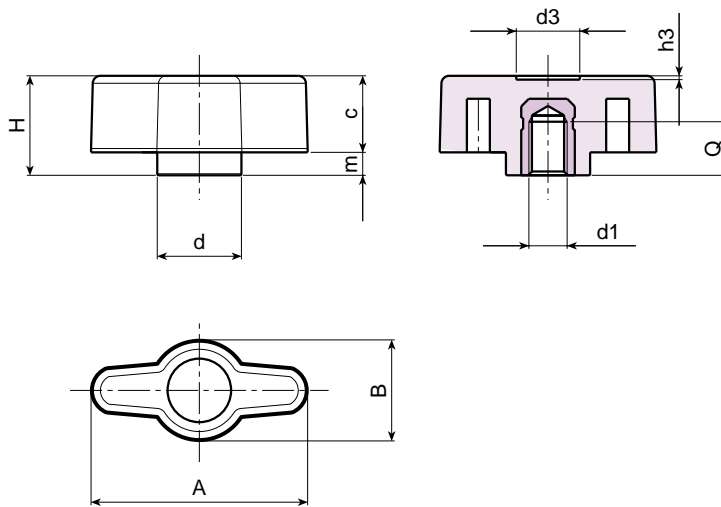

Art.	A	B	H	m	c	d	d3	h3	d1	Q	Weight (gr)
L747-28 M4	28	13	13	3	10	11	8	0,5	M4	8	4
L747-28 M5	28	13	13	3	10	11	8	0,5	M5	8	5
L747-28 M6	28	13	13	3	10	11	8	0,5	M6	8	6



BOTECA

ART. L748

28mm. WINGNUT WITH RIGHT THROUGH THREADED INSERT

MATERIAL:

Reinforced polyamide.
Oils and greases resistant.

SURFACE:

Satin.

COLOUR:

Black (RAL 9011).

MAIN INSERT:

Brass right through threaded bush.

SPECIAL REQUESTS:

- It is possible to supply the inserts in different materials, on request and for quantities.
- It is possible to supply colours as shown in the table at page 19, on request and for quantities.

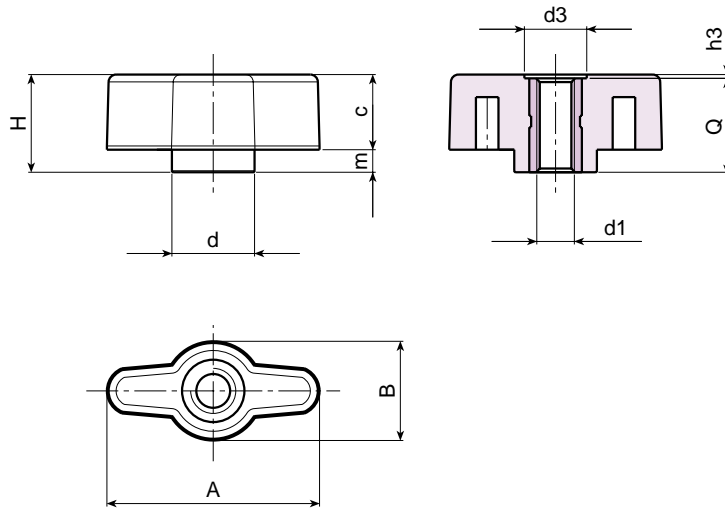

Art.	A	B	H	m	c	d	d3	h3	d1	Q	Weight (gr)
L748-28 M4	28	13	13	3	10	11	8	0,5	M4	12,5	5
L748-28 M5	28	13	13	3	10	11	8	0,5	M5	12,5	5
L748-28 M6	28	13	13	3	10	11	8	0,5	M6	12,5	6

W I N G N U T S A N D T H A N D L E S



BOTECA

ART. L749

28mm. WINGNUT WITH THREADED STUD

MATERIAL:

Reinforced polyamide.
Oils and greases resistant.

SURFACE:

Satin.

COLOUR:

Black (RAL 9011).

MAIN INSERT:

Zinc plated steel threaded stud.

SPECIAL REQUESTS:

- It is possible to supply the inserts with different lengths, on request and for quantities.
- It is possible to supply the inserts in different materials, on request and for quantities.
- It is possible to supply colours as shown in the table at page 19, on request and for quantities.

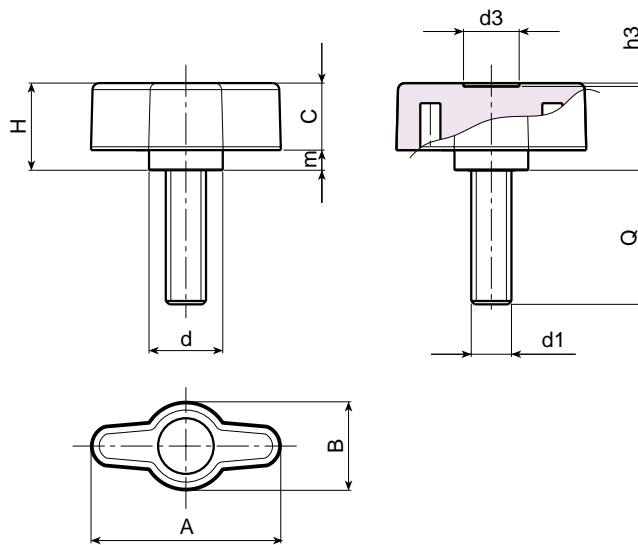











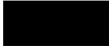

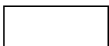

Art.	A	B	H	m	c	d	d3	h3	d1	Q	Weight (gr)
L749-28 M4	28	13	13	3	10	11	8	0,5	M4	10-16-20-25-30-40-50	5,5-6-6,5-7-7,5-8,5
L749-28 M5	28	13	13	3	10	11	8	0,5	M5	10-16-20-25-30-40-50	7-7,5-8-8,5-9-10-11
L749-28 M6	28	13	13	3	10	11	8	0,5	M6	10-16-20-25-30-40-50	7,5-8,5-9-10-11-12,5-14







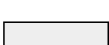







BOTECA

COLOUR CHART

R A L

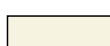
COLOUR		RAL	CODE
Black		9011	01
Orange		2004	02
Orange		2011	03
White		9010	04
Blue		5002	05
Blue		5005	06
Blue		5015	07
Blue		5018	19
Blue		5019	21
Blue		5010	22
Yellow		1007	09
Yellow		1021	10
Grey		7024	12
Grey		7035	13
Red		3000	16
Green		6024	17

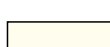
O T H E R C O L O U R S

COLOUR		REF.	CODE
White		-	52
Blue		-	53
Blue		pant. 645 U	54
Blue		pant. 300	55
Grey		-	57
Grey		-	59
Grey		NCS 7500	60
Red		-	64
Red		-	65
Natural		-	66
Green		-	70
Brown		-	71
Cream		-	72
Violet		-	73





BOTECO Spa - 36010 ZANÈ (VI) ITALY
Via L. Pettinà, 16 (side street of Via Cuso)
P.O. BOX 63 36010 Zanè
Switchboard Tel. ++39-0445.316411 - Fax ++39-0445.316400
Sales Office Fax ++39-0445.316401
Administration Fax ++39-0445.316402
E-Mail: boteco@boteco.it - sales@boteco.it
administration@boteco.it - Home Page: www.boteco.it

AUTHORISED RESELLER

